

Power HT-A 135-650 kW

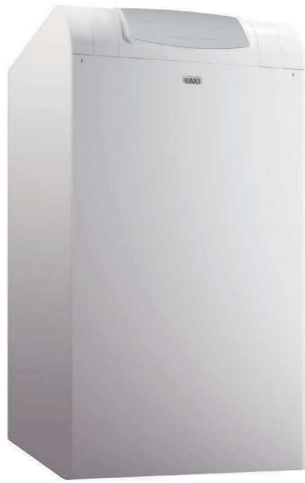

- Aluminium-silicon exchanger with glass wool insulation: high efficiency and reliability and long life
- Low emissions pre-mixing burner
- Digital control panel with back-lighted LCD display and advanced electronics to manage single and cascade installations (flue system to install up to 2 boilers in cascade)
- Easy to transport and to install
- Included outdoor sensor
- Circulating pump not included inside the boiler

Hydraulic system

Hydraulic connections on the rear side
Sticking pump check system
Flow and return NTC sensors
Premixed low-emissions burner

Thermoregulation system

Built-in climatic regulation
(outdoor sensor included)
Mixed zones systems
(high and low temperatures)
zone controllers as optional
Cascade system installation option
(up to 16 boilers)
NTC sensor for DHW cylinder
control option
Heating and DHW scheduler
integrated in the control panel

Control system

Full electronic anti-frost device
Electronic thermometer
Flow over-temperature thermostat

Outputs from 135 to 650 kW

Power HT-A		1135	1180	1230	1280	1320	1430	1500	1650
Maximum heat input (heating)	kW	125	170	215	260	300	300	469	610
Minimum heat output	kW	20	28	35	42	48	48	95	122
Rated heat output (80/60°C) <i>Prated</i>	kW	121,6	165,8	210,1	254,5	294,3	294,3	459	595,7
Minimum heat output (80/60°C)	kW	19,2	26,8	33,5	40,2	47,1	47,1	93	119,2
Maximum heat output (50/30°C)	kW	133,1	181,3	229,6	278,1	322,1	322,1	496,6	644,8
Minimum heat output (50/30°C)	kW	21,3	29,8	51,2	62	63,2	63,2	102,8	131,5
Useful heat output at 30% of rated heat output and low temperature regime** P_{u1}	kW	40,8	55,5	69,7	84,4	97,3	97,3	-	-
Efficiency η_n (lower calorific value) - Average temperature 70°C	%	97,3	97,5	97,9	98	98	98,2	98,3	98,5
Efficiency at 30% (lower calorific value) - Return temperature 30°C	%	108,8	108,8	105,4	105,6	105,7	105,9	105,8	105,7
Useful efficiency at rated heat output and high temperature regime** η_{h1}	%	87,7	87,9	88	88,2	88,3	88,3	-	-
Useful efficiency at 30% of rated heat output and low temperature regime** η_{l1}	%	98	98	97,4	97,5	97,4	97,5	-	-
Seasonal space heating energy efficiency η_{ss}	%	93	93	93	93	93	93	93	93
NOx emissions	mg/kWh	38	38	39	39	39	36	< 56	< 56
Maximum pressure heating circuit	bar	6	6	6	6	6	6	6	6
Maximum inlet temperature heating circuit	°C	90	90	90	90	90	90	90	90
Heating temperature range	°C	25-80	25-80	25-80	25-80	25-80	25-80	25-80	25-80
Water content	l	29	34	38	45	53	72	84	106
Dual flue system	mm	160	160	200	200	200	250	250	250
Maximum flue mass flow rate	kg/s	0,057	0,077	0,097	0,118	0,136	0,189	0,22	0,286
Minimum flue mass flow rate	kg/s	0,009	0,013	0,016	0,019	0,022	0,039	0,046	0,059
Maximum flue temperature	°C	61	61	60	61	60	64	61	64
Dimensions (h x w x d)	mm	1455x692x1208	1455x692x1171	1455x692x1264	1455x692x1357	1523x692x1882	1523x692x1882	1525x692x2192	1525x692x2192
Net weight	kg	205	340	285	314	344	540	598	674
Gas type									
Power consumption	W	170	200	330	350	410	463	583	750
Auxiliary electrical power consumption - Full load e_{lmax}	kW	170	200	330	350	410	463	583	750
Auxiliary electrical power - Partial load e_{lmin}	kW	31	34	40	46	51	60	-	-

²⁾ In case of Grundfos Magna modulating pump installation a signal converter (230V / 0-10V KPM) must be ordered

Dimensions Power HT-A 135-320 kW

Power HT 1.135 - 1.320

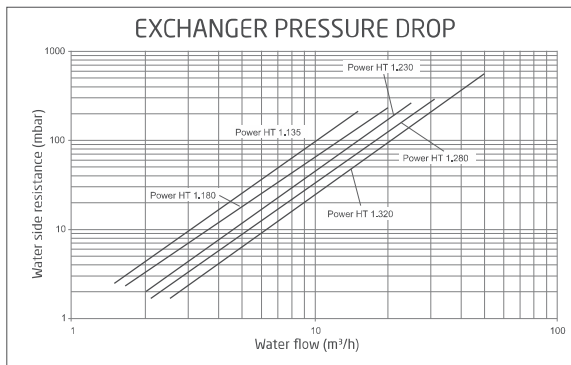
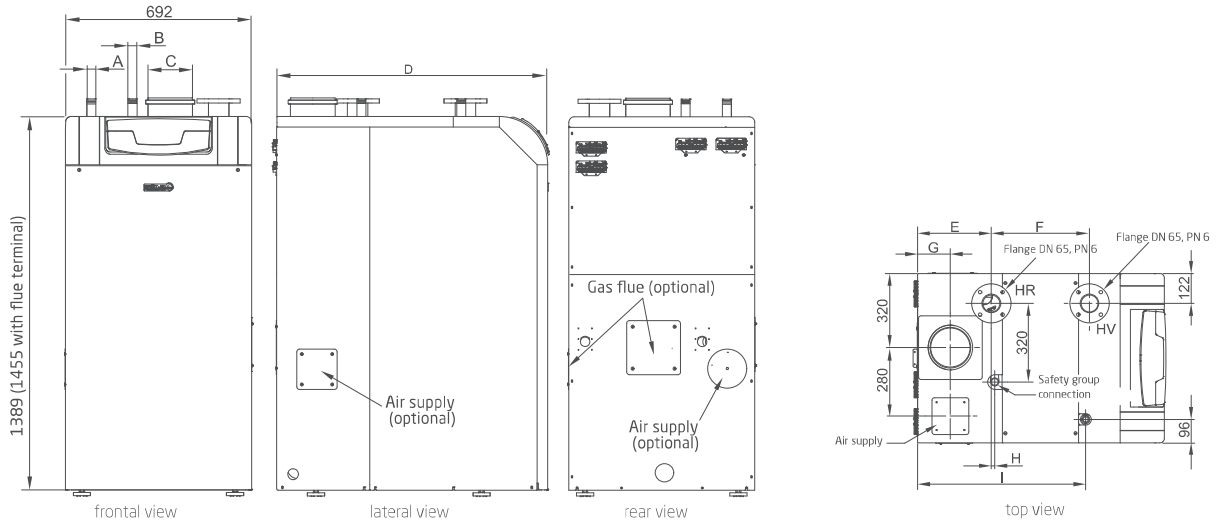

Model	Power HT 1.135	Power HT 1.180	Power HT 1.230	Power HT 1.280	Power HT 1.320
A	R 1"	R 1½"	R 1½"	R 1½"	R 1½"
B	R 1"	R 1"	R 1¼"	R 1¼"	R 1¼"
C	160	160	200	200	200
D	1008	1008	1171	1264	1357
E	301	301	351	351	351
F	401	401	514	607	700
G	134	134	163	163	163
H	14	14	14	14	14
I	687	687	851	944	1037

Installation instructions Power HT-A 135-320 kW

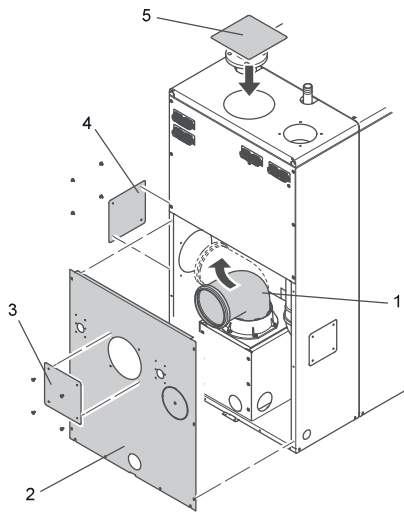

1. Remove lower rear wall (2) of the Power HT
2. Remove the gas connection leading upward and insert a 90° bend (1)
3. Turn 90° bend (1) in the desired position (side or towards the rear)
4. Remove either the rear cover plate (3) or the side cover plate (4)
5. Mount lower rear wall (2)

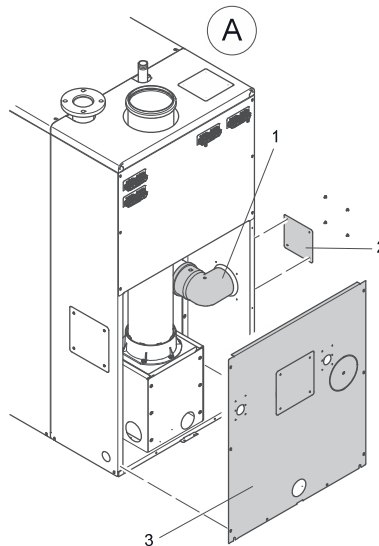

Side supply air connection (A)

1. Remove lower rear wall (3)
2. Remove the covering panel (2)
3. Mount the bend of the intake pipe (1)
4. Turn intake pipe elbow into the side position (1)
5. Mount lower rear wall (3)

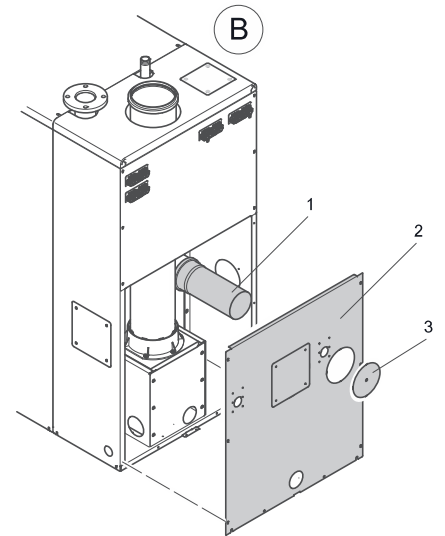

Rear supply air connection (B)

1. Remove lower rear wall (2)
2. Take out cover plate (3)
3. Mount straight intake pipe
4. Mount lower rear wall (2)

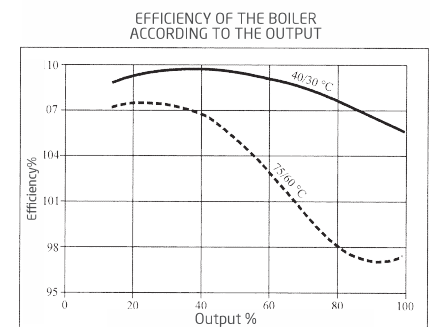
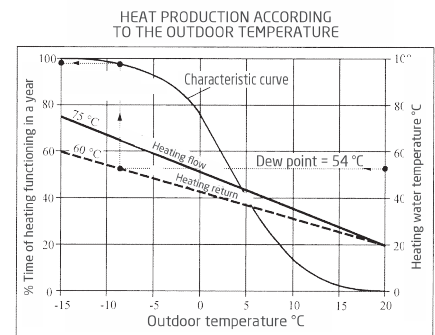
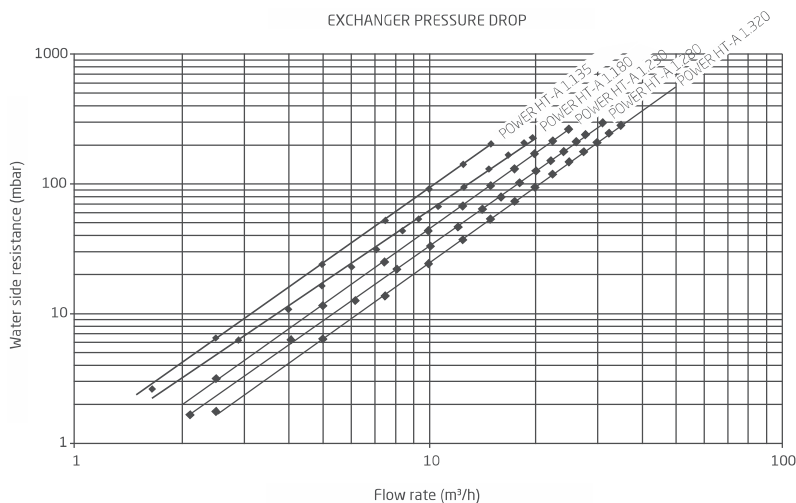

Dimensions Power HT-A 430-650 kW

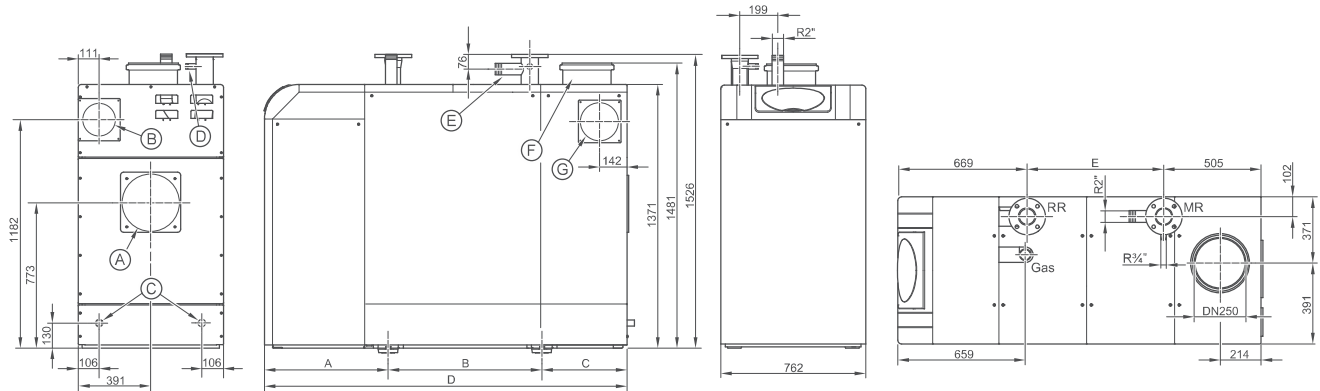

Power HT-A		1.430	1.500	1.650
A	mm	642	642	642
B	mm	798	1009	1009
C	mm	442	540	540
D	mm	1882	2192	2192
E	mm	709	1018	1018
MR	Heating system flow		Flange DN 80 PN 6	
RR	Heating system return		Flange DN 80 PN 6	
Gas	Gas inlet		R2" outer thread	
(A)	Rear flue outlet (optional)		DN 250	
(B)	Rear supply air connection		∅ 160	
(C)	Condensate drain (on the right/on the left)		DN 32	
(D)	Safety group connection		R3/4" outer thread	
(E)	Safety valve connection		R2" outer thread	
(F)	Flue outlet		DN 250	
(G)	Side supply air connection (optional)		∅ 160	

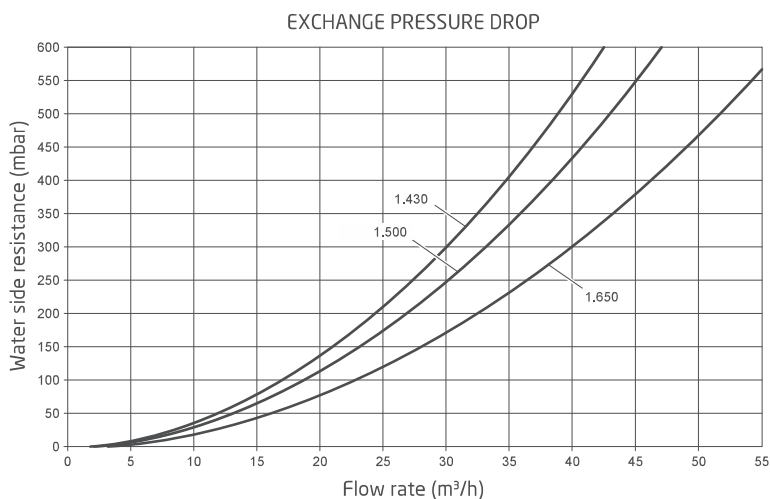

Installation instructions Power HT-A 430-650 kW

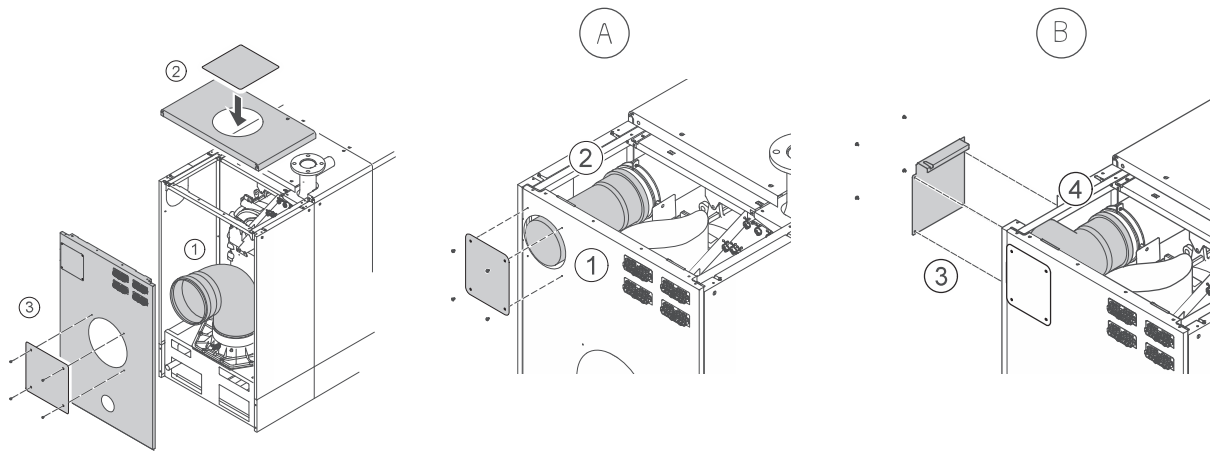

1. Remove upper and lower rear panel of the Power HT-A
2. Remove the flue connection leading upward (2) and insert a 90° bend (1)
3. Mount the cover plate (2)
4. Remove the back cover (3)
5. Mount upper and lower rear panel of the Power HT-A

Rear supply air connection (A)

1. Remove the upper panel
2. Take out cover plate (1)
3. Mount straight intake pipe (2)
4. Mount the upper panel

Side supply air connection (B)

1. Remove the upper panel
2. Remove the side covering panel (3)
3. Mount the bend of the intake pipe (4)
4. Mount the upper panel

Max lengths for the flue pipes with room air dependent working (type B installation)

Model		Power HT 1.430	Power HT 1.500	Power HT 1.650
Flue pipe ø	mm	250	250	250
Max L. pipe inc. 90° bend	m	50	50	50

These lengths are only for single boilers

Decrease of the total lengths of the flue pipes:

- 1 piece 90° bend: 5 m
- 1 piece 45° bend: 2 m
- 1 piece 15° bend: 1 m