

High output condensing systems

Power HT+ 50-250 kW



(1) Products with nominal output >70 kW are not subjected to energy labelling according to ErP regulation

Hydraulic system

- Stainless steel premixing burner with modulating fan
- Stainless steel water/flue exchanger
- System to prevent pump sticking operating every 24 hours
- Flow and return NTC sensor

Thermoregulation system

- Built-in remote control and climatic regulator
- Built-in climatic regulation (with outdoor sensor supplied as optional)
- Mixed zones system (high and low temperatures) installation option
- Cascade system installation option (up to 16 boilers)
- NTC sensor for DHW cylinder control option

Control system

- Programmable room unit for heating and DHW
- Overheat limit thermostat of the water/flue exchanger
- Low water pressure switch
- Heating circuit digital manometer
- Full anti-frost device
- Control device for water circulation
- Electronic thermometer
- Complete range of accessories for single and cascade installations

- Wide modulation ratio up to 1:9 (1:5 mod. 1.130, 1.150, 1.200 and 1.250) better efficiency and noiseless operation
- The new models 1.130 and 1.150 have the same size of 90-110 kW models
- High efficiency wide modulation circulating pump available in the hydraulic connection accessory
- Heat exchanger, with combustion chamber and hydraulic circuit, composed by stainless steel coils
- Fanned flue models with coaxial or dual flue pipes
- Control panel with wide text display and protection cover
- Enhanced electronics allows to manage cascade installations up to 16 boilers
- Simplified maintenance operations: frontal access to the internal components
- Maximum operating pressure: 4 bar (6 bar mod. 1.130, 1.150, 1.200 and 1.250)
- Wide range of accessories

Outputs from 50 to 250 kW

Power HT+	Heating only									
	1.50	1.70	1.90	1.110	1.130	1.150	1.200	1.250		
Maximum heat input (heating)	kW	46,3	65,9	87,4	104,9	123,8	143	191	240	
Minimum heat output	kW	5,1	7,4	9,7	11,7	24,8	28,6	31,8	40	
Rated heat output (80/60°C) <i>Prated</i>	kW	45	65	85	102	121,5	140,3	185,9	232,8	
Minimum heat output (80/60°C)	kW	5	7,2	9,4	11,4	24,3	28,1	31	38,8	
Maximum heat output (50/30°C)	kW	48,5	70,2	91,8	110,2	130,6	150,9	200	250	
Minimum heat output (50/30°C)	kW	5,4	7,8	10,2	12,3	26,2	30,2	33,1	41,7	
Useful heat output at 30% of rated heat output and low temperature regime** <i>P_u</i>	kW	15	21,7	28,3	34	40,4	46,6	36	46	
Seasonal space heating energy efficiency class		A	A							
Efficiency η_n (lower calorific value) - Average temperature 70°C	%	97,4	97,2	97,3	97,2	98,1	98,1	97,32	97,02	
Efficiency at 30% (lower calorific value) - Return temperature 30°C	%	108,4	108,1	108,2	108,1	108,5	108,5	109,1	109,1	
Useful efficiency at rated heat output and high temperature regime** <i>\eta_d</i>	%	87,7	87,6	87,7	87,6	88,4	88,4	87,7	87,4	
Useful efficiency at 30% of rated heat output and low temperature regime** <i>\eta_l</i>	%	97,7	97,4	97,5	97,4	97,8	97,8	98,3	98,3	
Seasonal space heating energy efficiency <i>\eta_s</i>	%	93	93	93	93	93	93	94	94	
NOx emissions	mg/kWh	27	31	36	22	17	23	37	39	
Maximum pressure heating circuit	bar	4	4	4	4	6	6	6	6	
Maximum inlet temperature heating circuit	°C	85	85	85	85	85	85	85	85	
Heating temperature range	°C	25-80	25-80	25-80	25-80	25-80	25-80	25-80	25-80	
Water content	l	2,81	4,98	8,34	9,83	10	11	13	15	
Dual flue system	mm	80	80	110	110	110	110	150	150	
Maximum flue mass flow rate	kg/s	0,075	0,111	0,144	0,169	0,201	0,23	0,322	0,411	
Minimum flue mass flow rate	kg/s	0,007	0,014	0,018	0,018	0,043	0,05	0,054	0,069	
Maximum flue temperature	°C	92	76	70	70	70	70	80	80	
Dimensions (hxwx dx)	mm	904x600x681			1221x600x681			1238x600x1410		
Net weight	kg	60	70	104	109	126	132	212	232	
Gas type		Natural Gas/LPG								
Power consumption	W	100	117	146	185	187	283	242	369	
Auxiliary electrical power consumption - Full load <i>el_{max}</i>	kW	100	117	146	185	187	283	242	369	
Auxiliary electrical power - Partial load <i>el_{min}</i>	kW	23	24	24	24	51	52	47	48	

* High temperature regime: 60°C return temperature at heater inlet and 80°C flow temperature at heater outlet

** Low temperature: 30°C return temperature (at heater inlet)

***Data not required for boilers with nominal output > 70 kW

▲To connect Ø 160 accessories, an adaptor is required

Cascade installation scheme

HYDRAULIC SCHEME - CONNECTIONS

Cascade of Power HT+ boilers for heating (1 direct zone + 3 mixed zones), solar system for DHW production with double coil tank and boiler integration.

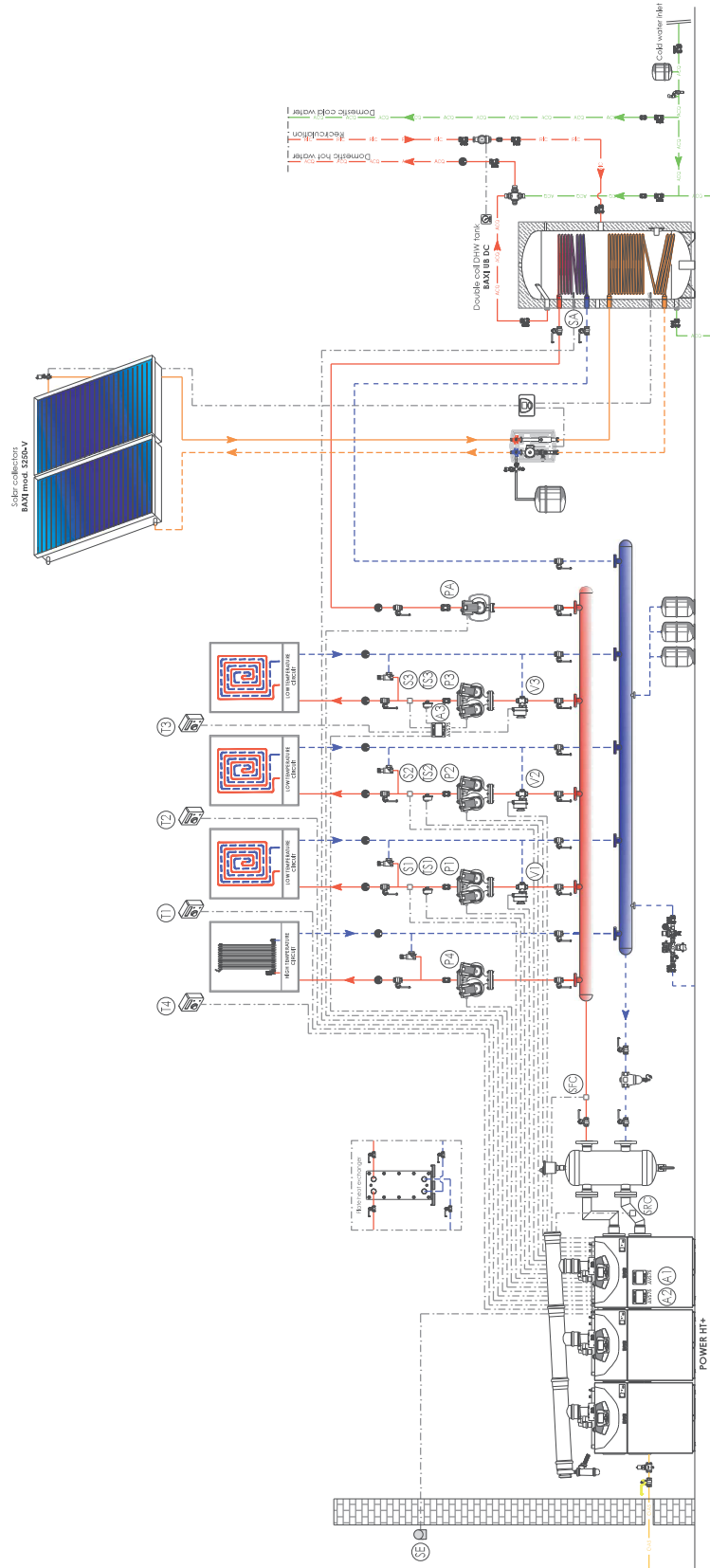

Dimensions Power HT+ 50-250 kW

Power HT+ 1.50 - 1.70

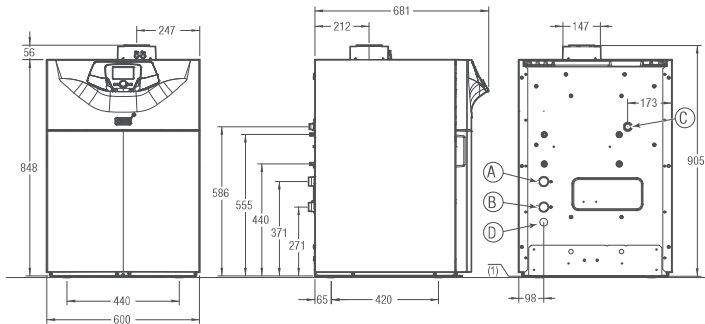

- 1 Heating system return (G1")
- 2 Heating system flow (G1")
- 3 Gas inlet (G3/4")
- 4 Condensing trap (DN18)
- (1) Adjustable feet

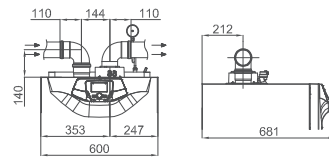

Concentric flue: Ø 80/125 Condotti
Dual flue: Ø 80

Power HT+ 1.90 - 1.110 - 1.130 - 1.150

Hydraulic connections Power HT+ 1.90 - 1.110

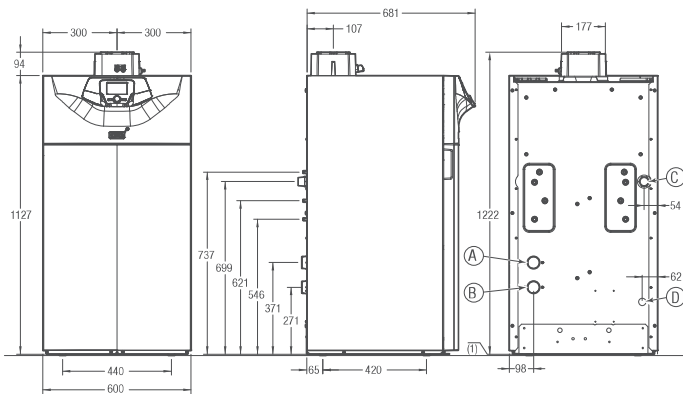

- A Heating system return (G1-1/2")
- B Heating system flow (G1-1/2")
- C Gas inlet (G1")
- D Condensing trap (DN18)
- (1) Adjustable feet

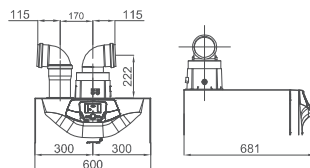

Concentric flue: Ø 110/160
Dual flue: Ø 110

Hydraulic connections Power HT+ 1.130 - 1.150

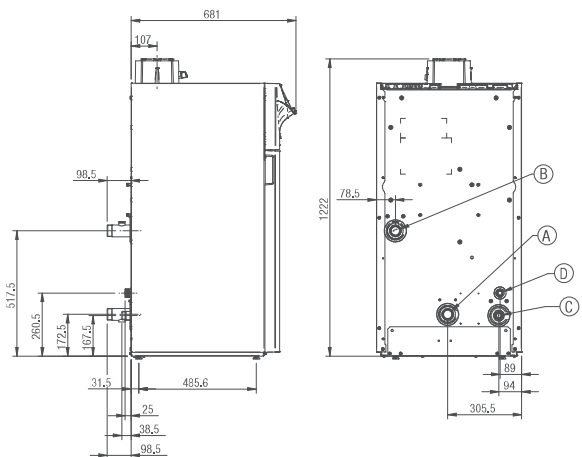

- A Heating system return (G1-1/2")
- B Heating system flow (G1-1/2")
- C Gas inlet (G1")
- D Condensing trap Ø 30

Power HT+ 1.200 - 1.250

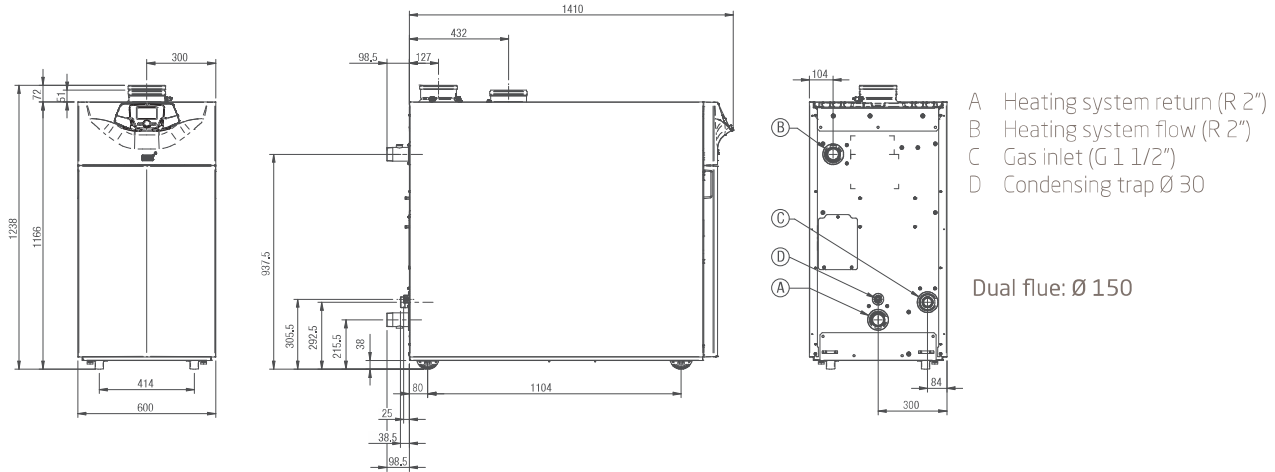

Power HT+ 1.50

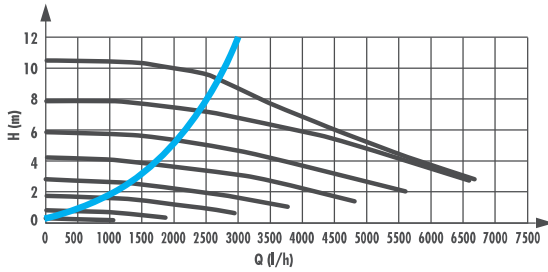

Power HT+ 1.70

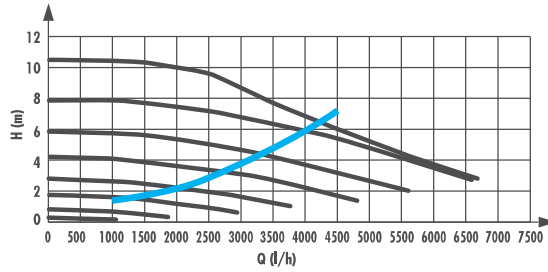

Power HT+ 1.90

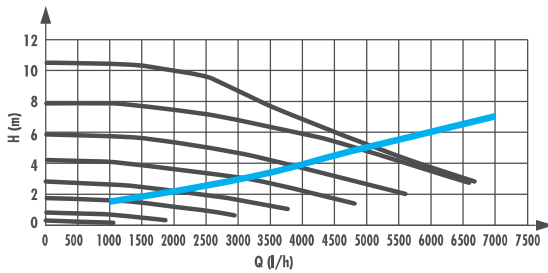

Power HT+ 1.110

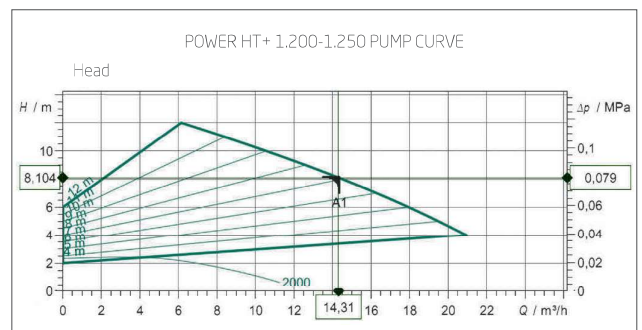
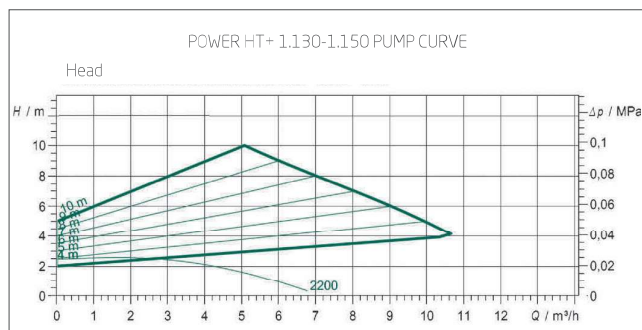
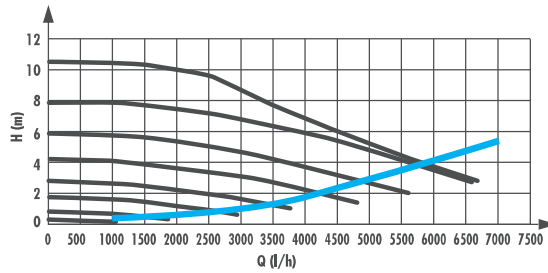

Flue systems

Flue type B_{23p} - maximum length of the pipes

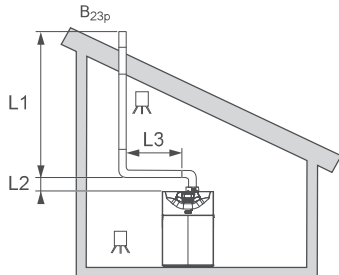

Power HT+ 1.50 - 1.70

Configuration	Flue type		Power HT+ 1.50	Power HT+ 1.50	Power HT+ 1.70	Power HT+ 1.70
			mm	Ø 80	Ø 110	Ø 80
L3 < 2m + 2 elbows	(L1 + L2) rigid	m	20	56	8	56
L3 < 2m + 2 elbows	(L1 + L2) flexible	m	15	56	6	38
L3 < 5m + 2 elbows	(L1 + L2) rigid	m	-	56	-	56
L3 < 5m + 2 elbows	(L1 + L2) flexible	m	-	56	-	38

Power HT+ 1.90 - 1.110

Configuration	Flue type		Power HT+ 1.90	Power HT+ 1.90	Power HT+ 1.110	Power HT+ 1.110	Power HT+ 1.110
			mm	Ø 110	Ø 125	Ø 110	Ø 125
L3 < 2m + 2 elbows	(L1 + L2) rigid	m	20	56	56	56	-
L3 < 2m + 2 elbows	(L1 + L2) flexible	m	-	21	15	-	-
L3 < 5m + 2 elbows	(L1 + L2) rigid	m	24	56	-	43	56
L3 < 5m + 2 elbows	(L1 + L2) flexible	m	13	-	-	-	-

Power HT+ 1.130 - 1.150 - 1.200 - 1.250

Configuration	Flue type		Power HT+ 1.130	Power HT+ 1.150	Power HT+ 1.200	Power HT+ 1.250
			mm	Ø 110	Ø 110	Ø 160 *
L3 < 2m + 2 elbows	(L1 + L2) rigid	m	20	27	39	23
L3 < 2m + 2 elbows	(L1 + L2) flexible	m	7	9	19	13
L3 < 5m + 2 elbows	(L1 + L2) rigid	m	17	23	36	19
L3 < 5m + 2 elbows	(L1 + L2) flexible	m	-	6	15	10

* To connect Ø 160 accessories, an adaptor is required

Flue type C₁₃ - maximum length of the pipes

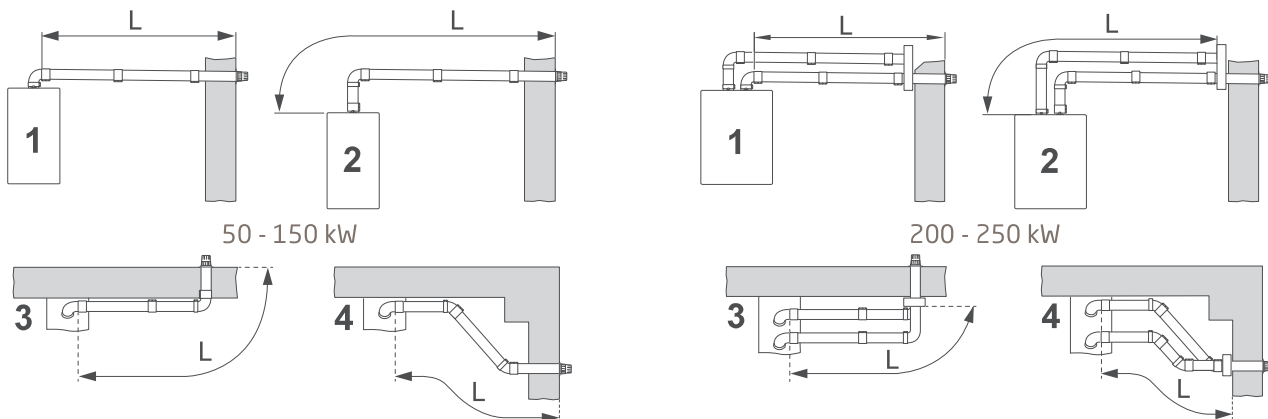

Power HT+ 1.50 - 1.70 - 1.90 - 1.110 - 1.130 - 1.150 - 1.200 - 1.250

Flue type		Power HT+ 1.50	Power HT+ 1.70	Power HT+ 1.90	Power HT+ 1.110	Power HT+ 1.130	Power HT+ 1.150	Power HT+ 1.200	Power HT+ 1.250
	mm	Ø 80 / Ø 125	Ø 80 / Ø 125	Ø 110 / Ø 160	Ø 110 / Ø 160	Ø 110	Ø 110	Ø 160 *	Ø 160 *
1	m	L < 10m	L < 10m	L < 10m	L < 10m	L < 8m	L < 8m	L < 45m	L < 22m
2	m	L < 10m	L < 10m	L < 10m	L < 10m	L < 8m	L < 8m	L < 45m	L < 22m
3	m	L < 9m	L < 9m	L < 9m	L < 9m	L < 7m	L < 7m	L < 42m	L < 19m
4	m	L < 9m	L < 9m	L < 9m	L < 9m	L < 7m	L < 7m	L < 41m	L < 18m

* To connect Ø 160 accessories, an adaptor is required

Dimensions Power HT+ 50-250 kW

Single installation

Power HT+ 1.50 - 1.70
(with hydraulic separator)

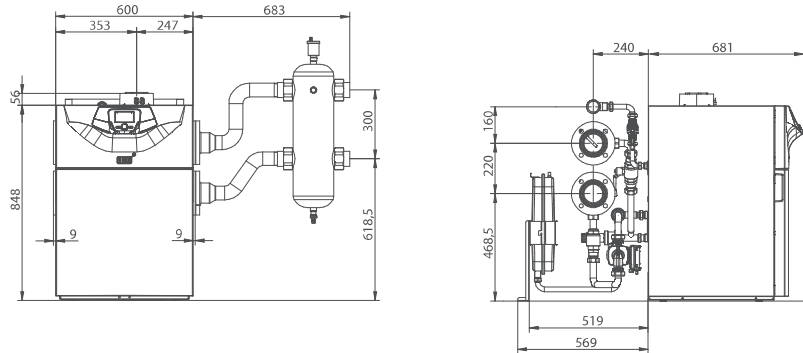

Power HT+ 1.90 - 1.110
(with hydraulic separator)

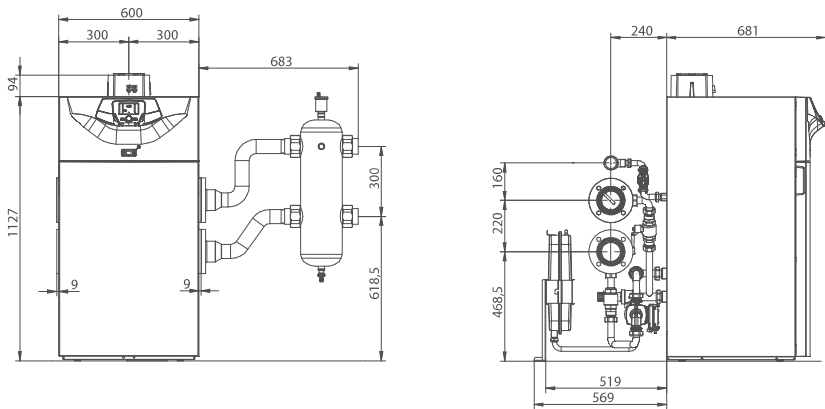

Power HT+ 1.130 - 1.150
(with hydraulic separator)

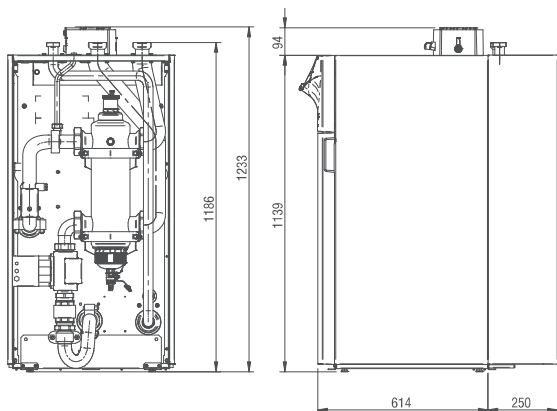

Power HT+ 1.130 - 1.150
(with plate exchanger)

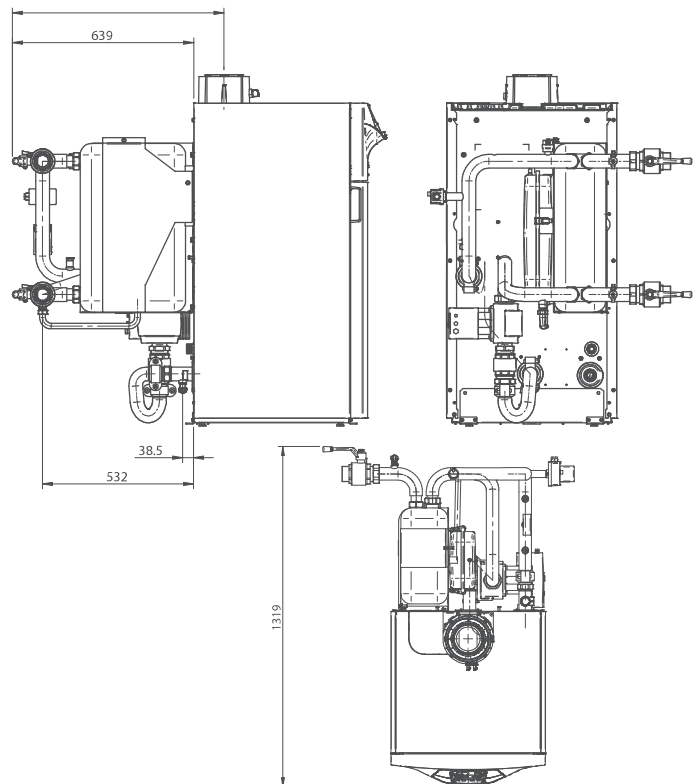

Power HT+ 1.200 - 1.250
(with hydraulic separator)

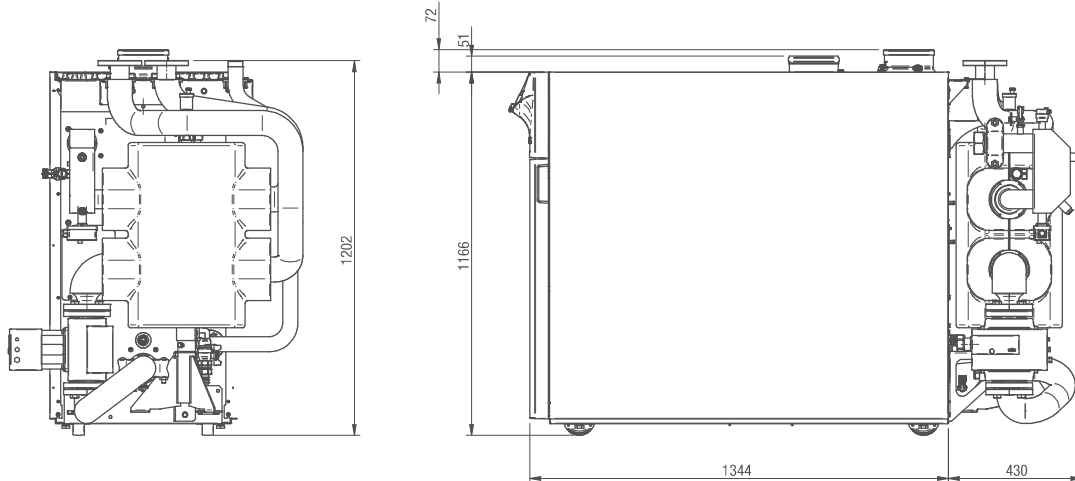

Power HT+ 1.200 - 1.250
(with plate exchanger)

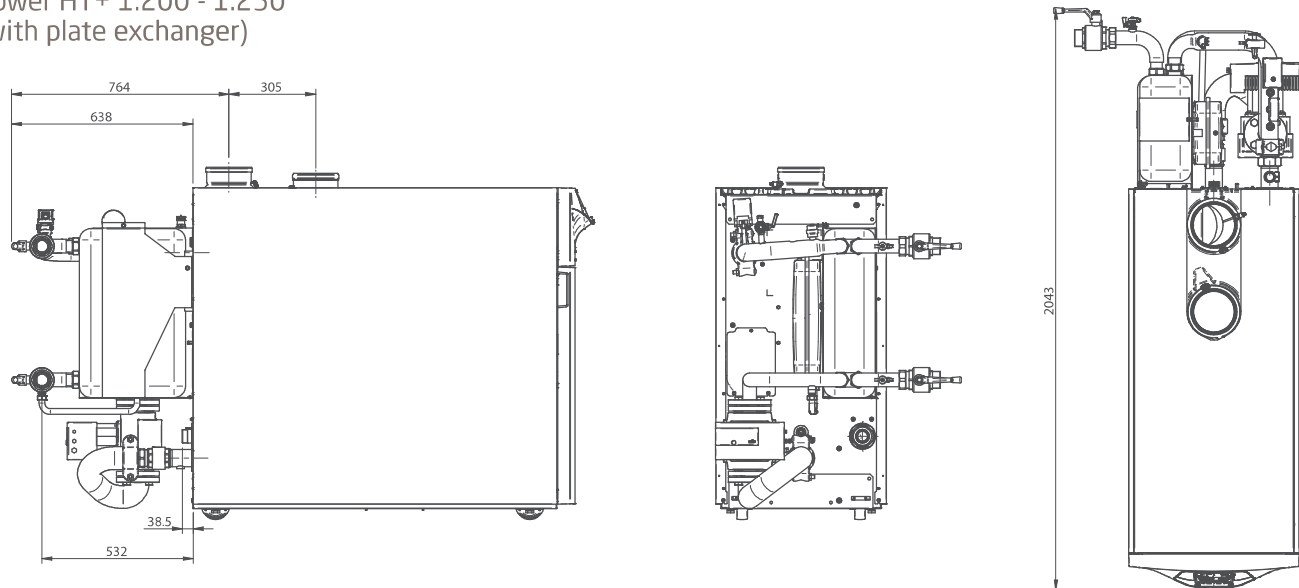

Cascade installation (2 boilers)

Power HT+ 1.50 - 1.70
(with hydraulic separator)

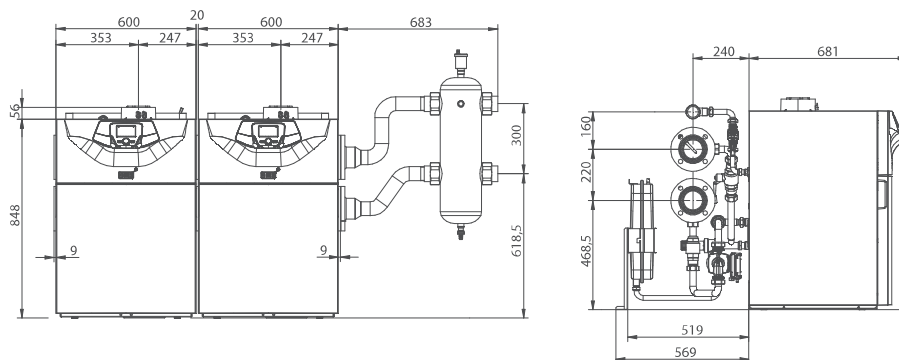

High output condensing systems

Power HT+ 1.90 - 1.110
(with hydraulic separator)

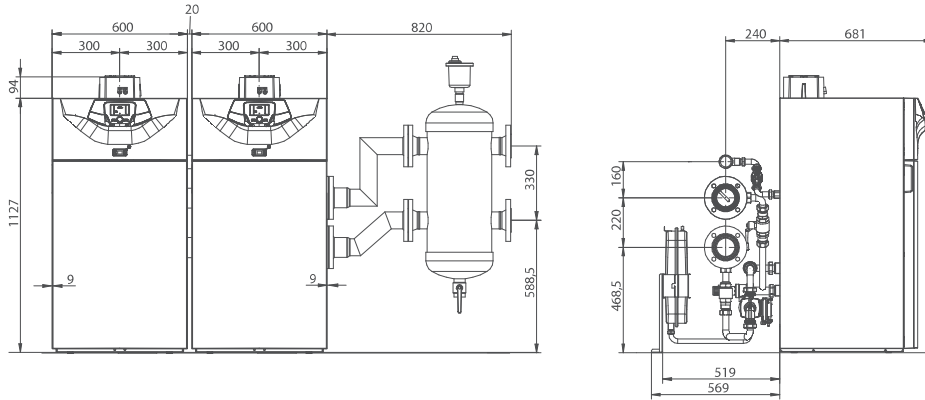

Power HT+ 1.130 - 1.150
(with hydraulic separator)

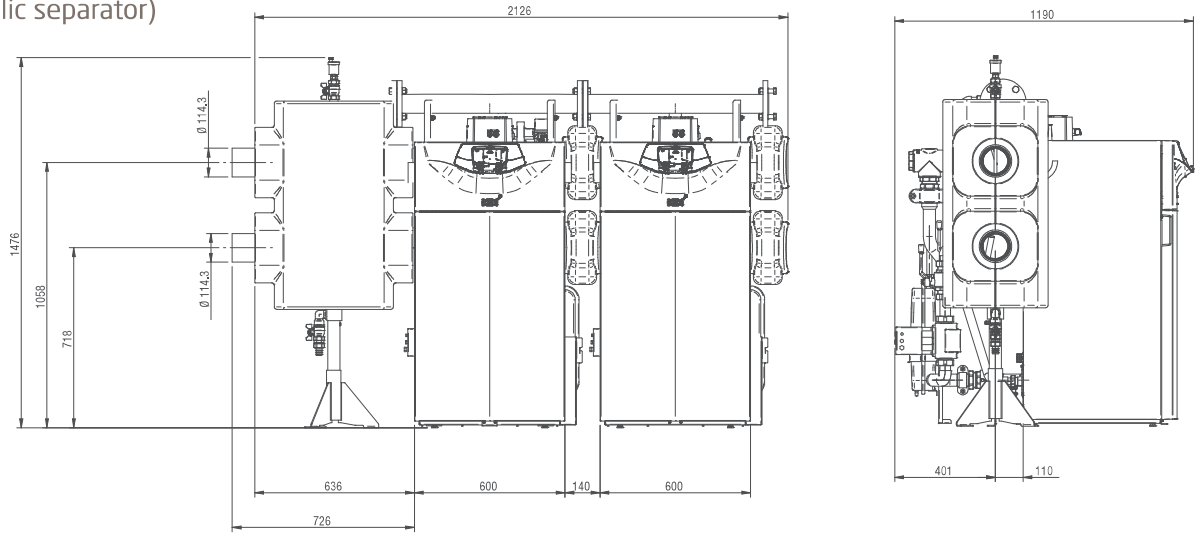

Power HT+ 1.200 - 1.250
(with hydraulic separator)

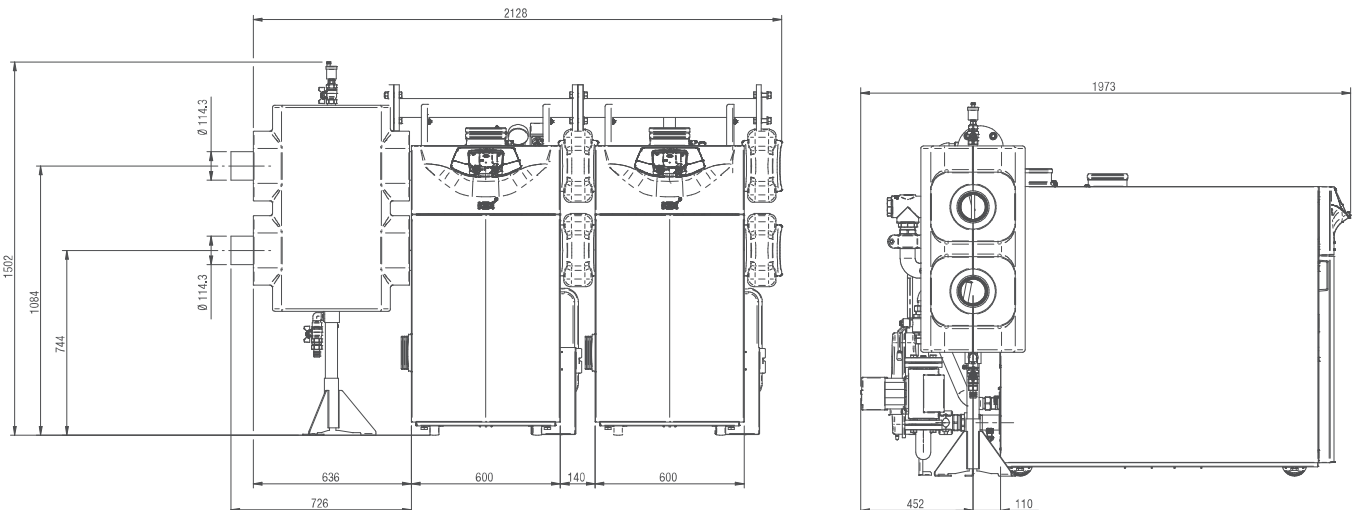

Cascade installation (3 boilers)

Power HT+ 1.50 - 1.70
(with hydraulic separator)

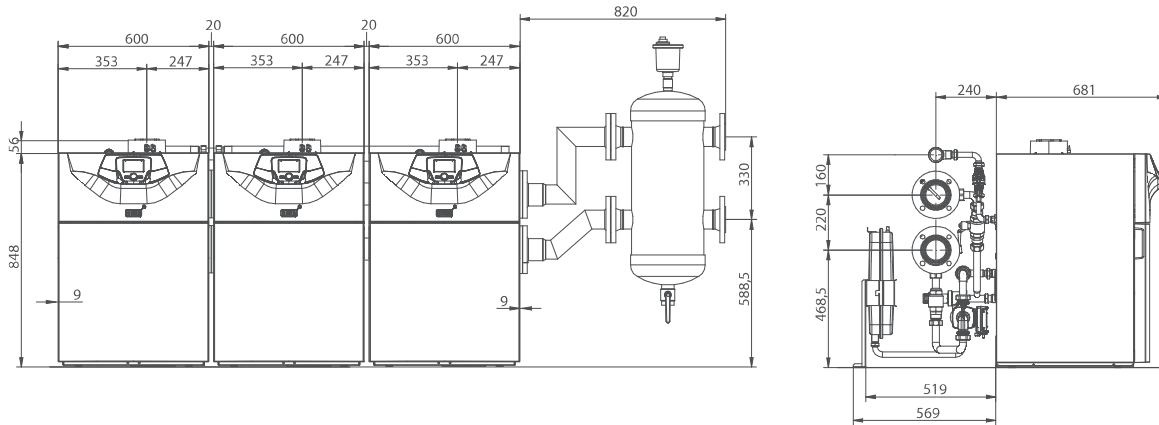

Power HT+ 1.90 - 1.110
(with hydraulic separator)

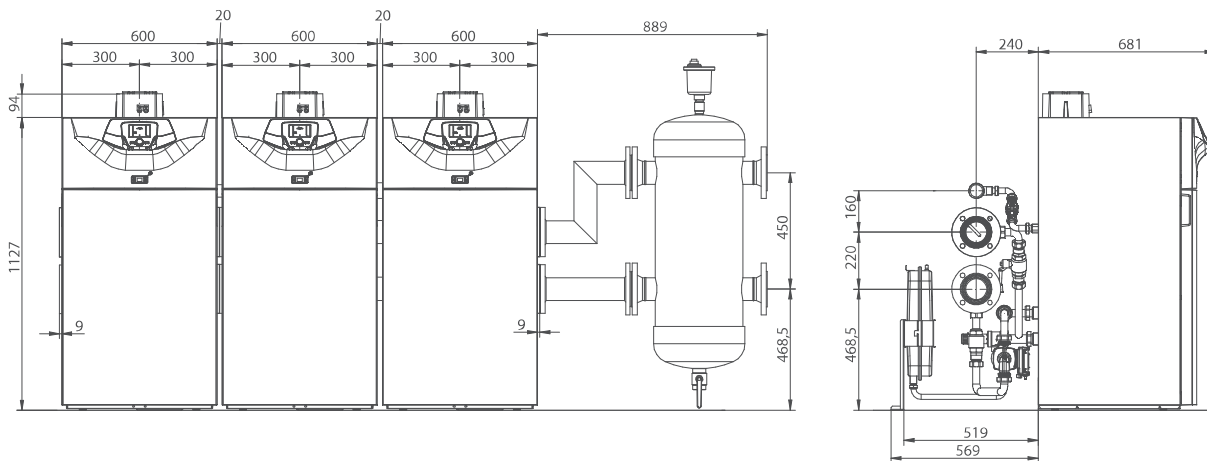

Power HT+ 1.130 - 1.150
(with hydraulic separator)

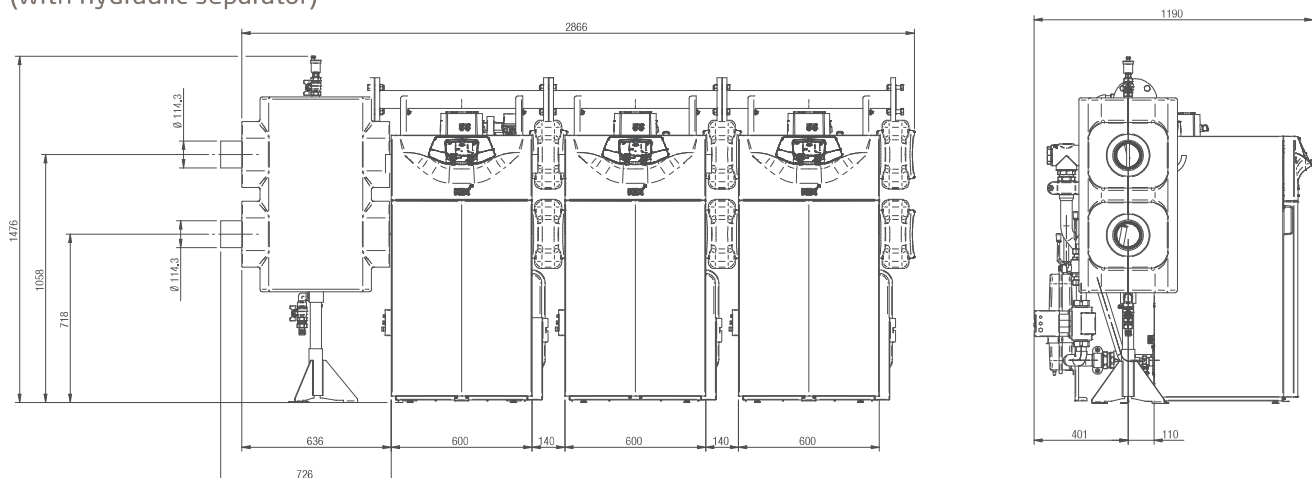

High output condensing systems

Power HT+ 1.200 - 1.250
(with hydraulic separator)

