

# High output condensing systems

## Power HT+ 50-250 kW



(1) Products with nominal output >70 kW are not subjected to energy labelling according to ErP regulation

### Hydraulic system

Stainless steel premixing burner with modulating fan  
Stainless steel water/flue exchanger  
System to prevent pump sticking operating every 24 hours  
Flow and return NTC sensor

### Thermoregulation system

Built-in remote control and climatic regulator  
Built-in climatic regulation (with outdoor sensor supplied as optional)  
Mixed zones system (high and low temperatures) installation option  
Cascade system installation option (up to 16 boilers)  
NTC sensor for DHW cylinder control option

### Control system

Programmable room unit for heating and DHW  
Overheat limit thermostat of the water/flue exchanger  
Low water pressure switch  
Heating circuit digital manometer  
Full anti-frost device  
Control device for water circulation  
Electronic thermometer  
Complete range of accessories for single and cascade installations

- Wide modulation ratio up to 1:9 (1:5 mod. 1.130, 1.150, 1.200 and 1.250) better efficiency and noiseless operation
- The new models 1.130 and 1.150 have the same size of 90-110 kW models
- High efficiency wide modulation circulating pump available in the hydraulic connection accessory
- Heat exchanger, with combustion chamber and hydraulic circuit, composed by stainless steel coils
- Fanned flue models with coaxial or dual flue pipes
- Control panel with wide text display and protection cover
- Enhanced electronics allows to manage cascade installations up to 16 boilers
- Simplified maintenance operations: frontal access to the internal components
- Maximum operating pressure: 4 bar (6 bar mod. 1.130, 1.150, 1.200 and 1.250)
- Wide range of accessories

## Outputs from 50 to 250 kW

Power HT+	Heating only								
	1.50	1.70	1.90	1.110	1.130	1.150	1.200	1.250	
Maximum heat input (heating)	kW	46,3	66,9	87,4	104,9	123,8	143	191	240
Minimum heat output	kW	5,1	7,4	9,7	11,7	24,8	28,6	31,8	40
Rated heat output (80/60°C) <i>Prated</i>	kW	45	65	85	102	121,5	140,3	185,9	232,8
Minimum heat output (80/60°C)	kW	5	7,2	9,4	11,4	24,3	28,1	31	38,8
Maximum heat output (50/30°C)	kW	48,6	70,2	91,8	110,2	130,6	150,9	200	250
Minimum heat output (50/30°C)	kW	5,4	7,8	10,2	12,3	26,2	30,2	33,1	41,7
Useful heat output at 30% of rated heat output and low temperature regime** <i>P<sub>u</sub></i>	kW	15	21,7	28,3	34	40,4	46,6	36	46
Seasonal space heating energy efficiency class		A	A						
Efficiency <i>P<sub>h</sub></i> (lower calorific value) - Average temperature 70°C	%	97,4	97,2	97,3	97,2	98,1	98,1	97,32	97,02
Efficiency at 30% (lower calorific value) - Return temperature 30°C	%	108,4	108,1	108,2	106,1	108,5	108,5	109,1	109,1
Useful efficiency at rated heat output and high temperature regime* <i>η<sub>h</sub></i>	%	87,7	87,6	87,7	87,6	88,4	88,4	87,7	87,4
Useful efficiency at 30% of rated heat output and low temperature regime** <i>η<sub>l</sub></i>	%	97,7	97,4	97,5	97,4	97,8	97,8	98,3	98,3
Seasonal space heating energy efficiency <i>η<sub>sp</sub></i>	%	93	93	93	93	93	93	94	94
NOx emissions	mg/kWh	27	31	36	22	17	23	37	39
Maximum pressure heating circuit	bar	4	4	4	4	6	6	6	6
Maximum inlet temperature heating circuit	°C	85	85	85	85	85	85	85	85
Heating temperature range	°C	25-80	25-80	25-80	25-80	25-80	25-80	25-80	25-80
Water content	l	2,81	4,98	8,34	9,83	10	11	13	15
Dual flue system	mm	80	80	110	110	110	110	150	150
Maximum flue mass flow rate	kg/s	0,075	0,111	0,144	0,169	0,201	0,23	0,322	0,411
Minimum flue mass flow rate	kg/s	0,007	0,014	0,018	0,018	0,043	0,05	0,054	0,069
Maximum flue temperature	°C	92	76	70	70	70	70	80	80
Dimensions (hxxwxd)	mm	904x600x681			1221x600x681			1238x600x1410	
Net weight	kg	60	70	104	109	126	132	212	232
Gas type		Natural Gas/LPG							
Power consumption	W	100	117	146	185	187	283	242	369
Auxiliary electrical power consumption - Full load <i>el<sub>max</sub></i>	kW	100	117	146	185	187	283	242	369
Auxiliary electrical power - Partial load <i>el<sub>min</sub></i>	kW	23	24	24	24	51	52	47	48

\* High temperature regime: 60°C return temperature at heater inlet and 80°C flow temperature at heater outlet

\*\* Low temperature: 30°C return temperature (at heater inlet)

\*\*\*Data not required for boilers with nominal output > 70 kW

▲To connect Ø 150 accessories, an adaptor is required

## Cascade installation scheme

### HYDRAULIC SCHEME - CONNECTIONS

Cascade of Power HT+ boilers for heating (1 direct zone + 3 mixed zones), solar system for DHW production with double tank and boiler integration.

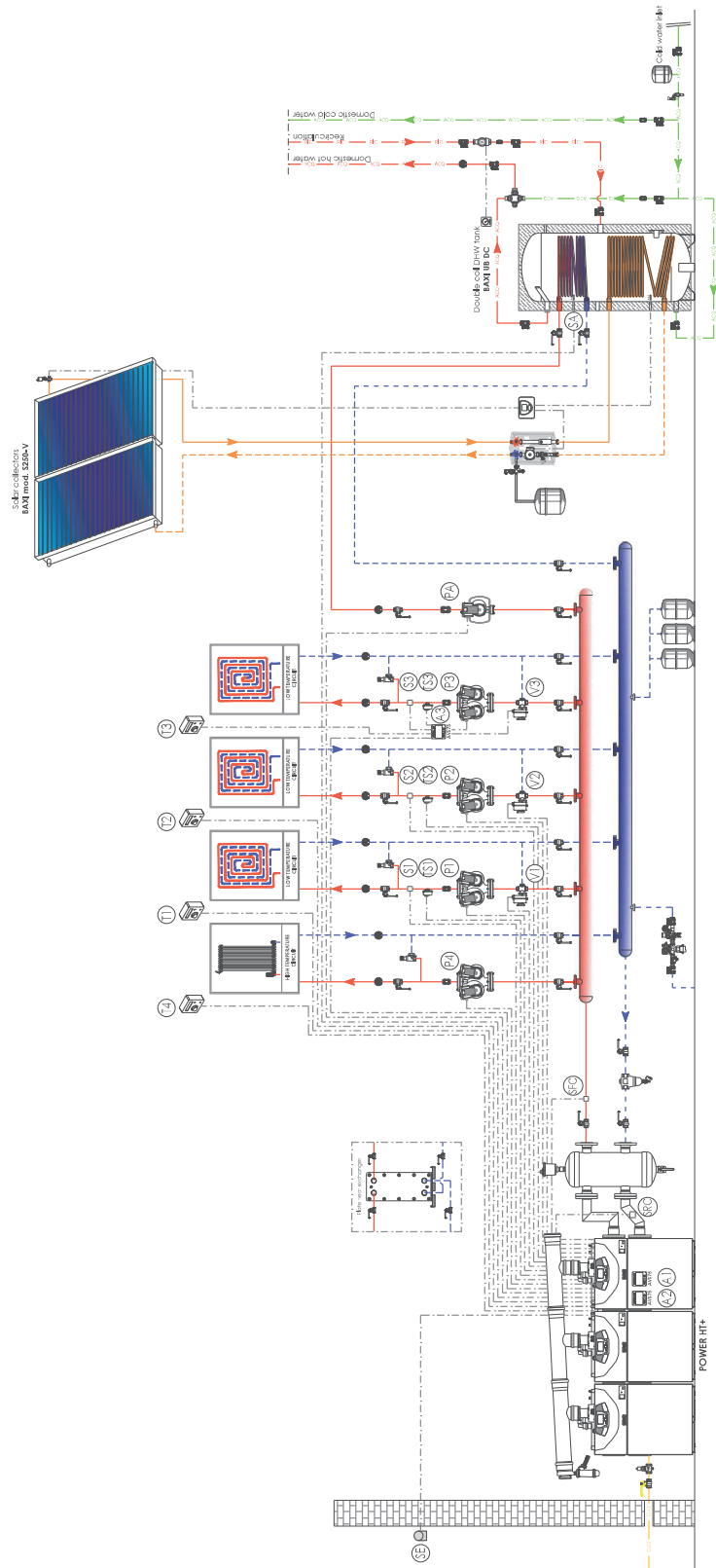

# High output condensing systems

## Dimensions Power HT+ 50-250 kW

### Power HT+ 1.50 - 1.70

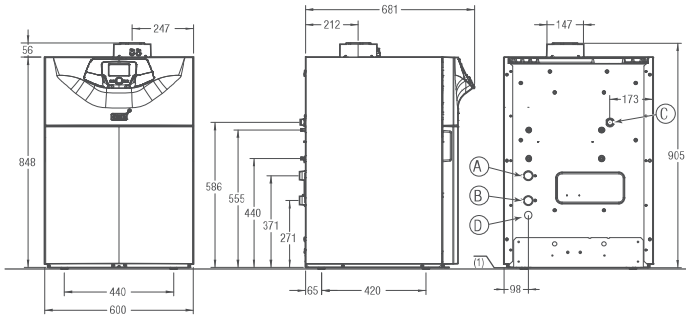

- 1 Heating system return (G1")
- 2 Heating system flow (G1")
- 3 Gas inlet (G3/4")
- 4 Condensing trap (DN18)
- (1) Adjustable feet

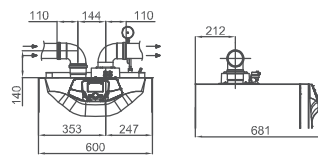

Concentric flue: Ø 80/125 Condotti  
Dual flue: Ø 80

### Power HT+ 1.90 - 1.110 - 1.130 - 1.150

Hydraulic connections Power HT+ 1.90 - 1.110

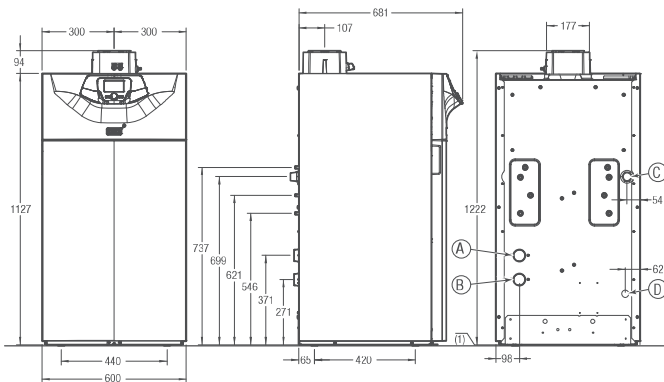

- A Heating system return (G1-1/2")
- B Heating system flow (G1-1/2")
- C Gas inlet (G1")
- D Condensing trap (DN18)
- (1) Adjustable feet

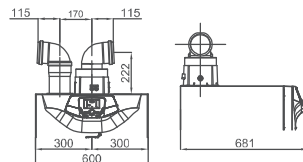

Concentric flue: Ø 110/160  
Dual flue: Ø 110

Hydraulic connections Power HT+ 1.130 - 1.150

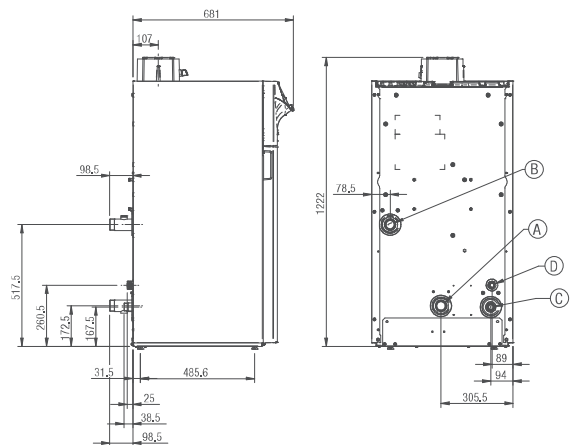

- A Heating system return (G1-1/2")
- B Heating system flow (G1-1/2")
- C Gas inlet (G1")
- D Condensing trap Ø 30

## Power HT+ 1.200 - 1.250

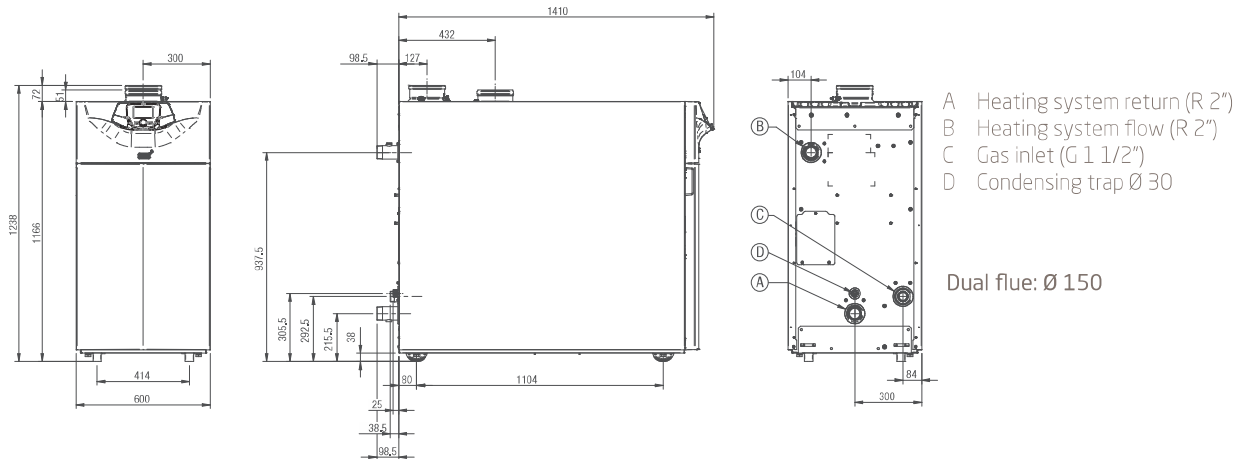

## Power HT+ 1.50

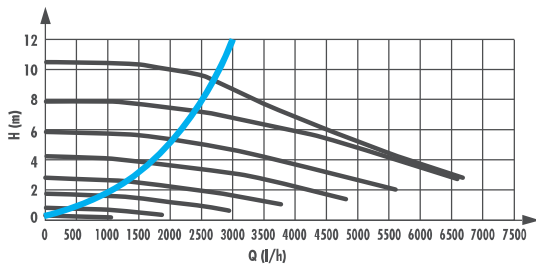

## Power HT+ 1.70

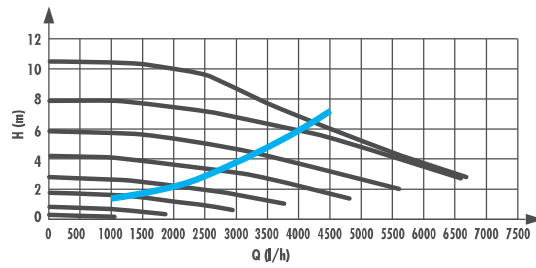

## Power HT+ 1.90

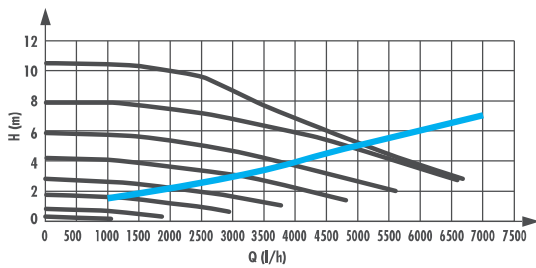

## Power HT+ 1.110

